

Dry vacuum cleaner – 400 Volt

EVOTEC



- All parts coming in contact with the product are made from stainless steel (1.4301)
- Side channel blower for permanent operation and EX-protection Type22
- Complete safety related equipment
- Comfortable lowering of the dirt container
- Also available with Longopac-disposal-system

EP 2122

EP 2130

EP 2140 ECO

EP 2155 ECO

2.200 to 5.500 watt
400 volt
240 to 340 mbar
330 to 500 m³/h
60 liter container

Available in types:



from 4,0 kW:



to 3,0 kW:



Robust industrial vacuum cleaner for sucking up all dry dust particles – from coarse dirt to fine dust (µm)

High quality standards – well-designed, silenced and maintenance-free turbine (side channel blower) as vacuum generator. Suitable for **three-shift-operation**.

Cyclone separator for better pre-separating of fine dust particle and coarse matter.

Effective, easy to use **filter cleaning** for long operating intervals without interruption.

Vacuum gauge for filter monitoring.

1st level filter:

Durable polyester needle-felt filter with **PUR-membrane**, dust class **M**, high filter effect for long durability.

2nd level filter:

“Absolut”- cartridge filter dust class **H (H14)**.

Patented, tool less **filter change** with **low contamination risk**.

Phase direction monitor and vacuum limit valve for the **faultless use of the device**.

Fast coupling with locking mechanism and rotating device for a secure connection of the suction hose.

Length of the connection cable: 8 m

On request with Longopac Disposal System: "Endless"

plastic bag for easy and contamination-free disposal of the suction material

Included in delivery:

3,5 m suction hose Ø 50 mm and crevice nozzle.



Type		EP 2122	EP 2130	EP 2140 ECO	EP 2155 ECO
Voltage	volt	400	400	400	400
Power output	watt	2.200	3.000	4.000	5.500
Max. airflow rate	m³/h	330	330	410	500
Max. negative pressure	mbar	240 / 300 max.	260 / 340 max.	240 / 300 max.	260 / 320 max.
Filter surface „M“	m²	2,2 or 3,2	2,2 or 3,2	3,2	3,2
Filter surface „H“	m²	+ 2,0	+ 2,0	+ 4,3	+ 4,3
Dirt container	l	60	60	60	60
Type of protection		IP 55	IP 55	IP 55	IP 55
Noise level	dB(A)	70	70	76	76
Suction connection	Ø mm	80	80	80	80
Dimension	cm	120x68x135	120x68x135	120x68x135	120x68x135
Weight	kg	150	160	180	190
Dust class M	Art.-No.	251-1040	251-1050	251-1060	251-1070
Dust cl. M/Type22	Art.-No.	251-1041	251-1051	251-1061	251-1071
Dust class H	Art.-No.	251-1042	251-1052	251-1062	251-1072
Dust cl. H/Typ22	Art.-No.	251-1043	251-1053	251-1063	251-1073



Explanation Details



EP 2122

EP 2130

EP 2140ECO

EP 2155ECO



Disposal options



Plastic disposal bag, antistatic ESD

Packing unit = 10 pcs



For dust-free disposal of dust particles (dust classes M and H)

Highly stable and „nail tested“

Perfect fit due to round bottom – no bypass necessary.

Suitable for:

25/35-l-container =	235-1011
60-l-container =	235-1021
100-l-container =	235-1031



Longopac - bag



„Endless“-bag for easy and dust free disposal of the absorbed matter. 20m tubular bag with cable straps to seal.

Packing unit = 4 units á 20 Meter

Stable **ESD-Quality**

Thickness: 68 mic. **235-1050**

Extra sturdy quality

(not ESD)

Thickness: 68 mic. **235-1060**

Options



Spark trap with metal knit insert

prevents the suction of sparks into the system. Different diameters for integration in pipe system or suction hose

Ø 80 mm	072-0628
Ø 100 mm	072-0629
Ø 150 mm	072-0630



Hose bracket

Optimal for the storage of long hoses.

Suitable for all models with 60 liter dirt container (EP1136, EP2122 ECO, EP2130 ECO, EP 2122, EP 2130, EP 2140 ECO, EP 2155 ECO)

Suitable for up to 10 m hose
053-3070

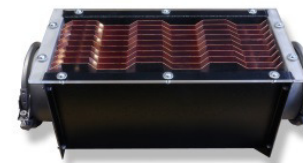

Spark trap

Prevents the suction of sparks into the vacuum cleaner. Due to the air redirection, the sparks bounce against the copper plates and expire. Via the detachable faceplate the trap can be cleaned.

connections Ø 80 mm	053-4000
connections Ø 150 mm	053-4001

Pocket filter



Dust class M

Polyester-needle felt with **PUR-Membrane**
(installed by default)
Non-stick properties – for sticky or adhesive dusts
Also for the suction of fine dust with abrasive nature (e.g. fiber glass)

1,75 m², Ø 400 mm = **054-20085B**
2,20 m², Ø 500 mm (fig) = **054-20086B**
3,20 m², Ø 500 mm = **054-20087B**
5,20 m², Ø 500 mm = **054-20088**



Dust class M

Robust polyester-needle felt with **PTFE-Membrane**
Non-stick properties – for sticky or adhesive dusts

Heat-resistant
Temporary (30 min.) up to 200 °C
Continuous up to 150 °C

Video on
You Tube

1,75 m², Ø 400 mm = **054-20115**
2,20 m², Ø 500 mm = **054-20116**
3,20 m², Ø 500 mm (fig) = **054-20117**
5,20 m², Ø 500 mm = **054-20118**



Dust class M

Polyester-needle felt with **antistatic PUR-Membrane**

Antistatic – for the suction of dust that can accumulate static charge

Food-safe – for the application in sensitive areas such as pharmaceutical or food production

1,75 m², Ø 400 mm = **054-20127**
2,20 m², Ø 500 mm (fig) = **054-20128**
3,20 m², Ø 500 mm = **054-20129**
5,20 m², Ø 500 mm = **054-20130**



Dust Class H (H14)

Absolute cartridge filter for all types of EVOTEC

Double-sided support grid,
to buy for replacement:

1,7 m², Ø 400 mm = **054-20018**
2,0 m², Ø 500 mm = **054-20027**
4,3 m², Ø 500 mm = **054-20033**



Bypass for standard disposal bags

Due to vacuum compensation, it allows the usage of standard disposal bags.

Consists of connection hose from dirt container to filter compartment, including Kamlock-connection for easy decoupling and re-coupling.

053-3030

Cartridge filter system with jet cleaning



Cartridge filter unit with Jet-cleaning

Filter surface 7,5 m², PTFE antistatic, with FDA certificate

Perfect for automatic and continuous cleaning of filter cartridge while sucking up very fine and dry dust particles.

Cleaning cycles are induced by the automatic control and can be defined as required.

The system cleans the filter elements in the cartridge with blasts of compressed air. It is not necessary to shut down the engine.

Filter cartridge class M, antistatic (standard). Combination with filter dust class H (H14) is possible.

Attention: external compressed air necessary!

Included in delivery:
Reservoir for compressed air, volume expansion, control unit, cartridge filter, cleaning unit

For models:

EP 2122, EP 2130, EP 2140 ECO,
EP 2150 ECO **053-3022**

EP 2140 and EP 2150 **053-3021**

To buy for replacement

conical, Filter surface 7,5 m², PTFE antistatic
054-20092



Filter cleanings and replacement filters



Atmospheric Pulse-cleaning (PPU)

Sudden atmospheric pressure cleans the pockets/pleats of the filter at defined time intervals. Including automatic controls

For Pocket filter from 1,75 m² and cartridge filter up to 5 m², 1 ¼" inch
053-3026

For Pocket filter from 2,2 m² and cartridge filter up to 10 m², 1 ½" inch
053-3025

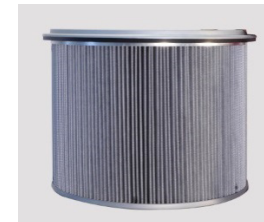

Cartridge filter – to buy for replacement for pulse-cleaning (PPU), Dust class M

5,0 m² electrically conductive
054-20123

5,0 m² PTFE electrically conductive
054-20122

10,0 m²
054-20102

10,0 m², V4A electrically conductive and food safe
054-20103

without picture

Electromechanical filter-cleaning

Automatic filter-cleaning after switching off the vacuum cleaner. The pockets or folds are set in vibration with a shaker motor and the dust is shaken off

universal
053-3027

Control Options



Frequency converter (FU)

For variable speed control and increased performance of the turbine.

Version for 230 Volt:

1,5 kW **054-6911**
2,2 to 3,0 kW **054-6912**

Version for 400 Volt:

1,5 kW **054-6921**
2,2 to 3,0 kW **054-6922**
4,0 to 5,5 kW **054-6923**
5,5 to 7,5 kW **054-6924**
7,5 to 11,0 kW **054-6925**
11,0 to 15,0 kW **054-6926**

Suitable holding console for the switch box please order as well: **054-40208**



Remote ON/OFF via cable (FSK)

24 volts with power supply unit (potential free contact), output voltage 24 volts AC with interconnection point, motor protection relay, switch = 0/automatic/hand.

If not in combination with FU, additional switch box is needed for FSK.

Without switch box **054-6931**
With switch box **054-6930**
holding console for switch box **054-40208**



Remote ON/OFF via radio (FSF)

With hand-held transmitter and receiver, operates up to 350 m distance.

If not in combination with FU, additional switch box is needed for FSK.

Without switch box **054-6933**
With switch box **054-6932**
holding console for switch box **054-40208**
Additional hand-held transmitter **054-60322**

Device Options



Activated carbon filter module

To absorb odors and fumes.

25-l-container filled with activated carbon, individual matching, suitable for all models with turbine chassis

053-2060



Electronic liquid level control

Can be ordered directly with the vacuum cleaner. The control allows the suction of liquids with a dry vacuum cleaner due to the flex probe.

The probe plunges into the dirt container and prevents the spilling over of liquids.

Only for dust classes M and H (not Type22).

Consisting of a flex probe, holder and electronics

053-3040

Pre-separator



Pre-separator 100 liters

Completely made of stainless steel with 4 swivel castors.

Different connector bends

Ø 60 + Ø 50 mm = **053-1090**

Ø 60 + Ø 40 mm = **053-1091**

Ø 50 + Ø 50 mm = **053-1092**

Ø 40 + Ø 40 mm = **053-1093**

Ø 40 + Ø 50 mm = **053-1094**

Attention: The suction hose needs two suction side fittings!

Floating system for pre-separator

for suction of liquids **053-1051**

Draining hose for pre-separator

universally suitable **053-3010**

Connection hose for the connection to the vacuum cleaner,

complete with fittings, length 2,0 m, Ø 60 mm

PUR = **053-3081**

Superflex = **053-3080**



Tandem connection set

For 100 liter or 150 liter pre-separators.

With this set the pre-separator can be combined with the industrial vacuum cleaner to form a mobile unit.

Incl. connection hose from pre-separator to vacuum cleaner (angled hose coupling)

Suitable for models

EP 1136, EP 2122 ECO und EP 2130 ECO
053-2070

Pre-separator



Filter- pre-separator V2A

60 liter dirt container with easy lowering via levers for the comfortable disposal of absorbed matters.

Robust chassis including accessory box.

Connection sleeve Ø 80 mm

Dust class M

including pocket filter 2,2 m² surface

053-2030

Matching absolute filter cartridge

dust class H - 2,0 m² surface

054-20027

Find suitable suction- and connection hoses for pre-separators at „accessories“.



Wet- pre-separator V2A

140 liter dirt container V2A with robust tilting chassis.

Dump hose for easy disposal of liquids.

Includes floating system for pre-separators

Connection sleeve Ø 60 and suction bend Ø 50 mm

Attention: The suction hose needs two suction side fittings!

053-1070

Pre-separator



Container with hinged floor 1000 liters
 With Ø 80-connections
 To pre-separate solids (e.g. turf, sand, etc.)
 Pull springs buffer the bottom flap during the discharging process.
 Automatic closure of the bottom flap when container is deposed.
 Unlocking per cable operation without leaving the lifter.
 Chain protection against sliding of the tines

053-2020 4.741,60 €



Tilting container pre-separator 500 liters
 With Ø 80-connections
 To pre-separate solids and liquids.
 Tilting in every height per cable control without leaving the lifter.
 Stable basic frame with fork pockets, favorable load center
 Protected against unintentional sliding and spilling

053-2010 2.969,50€

Suction arms



The suction arm allows the **punctual** suction directly at the point of origin. Due to the **self-supporting construction** simple to handle and easy to position.
 Antistatic design and therefore usable for the **use in ESD-areas** (grounded with a resistance of 1MΩ).

Size Ø 50 mm – ideal up to 3 kW
 Optimal for small coverage areas, e.g. in electronic industries, laboratories, dentistry, laser technologies, nail spa, gold smith etc.

Size Ø 75 mm – ideal from 3 kW
 Usable in many different sectors, e.g. laboratories, laser technology, chemical and pharmaceutical industry, food industry, schools, universities or machine industry.

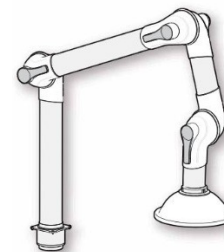

Suction arm ESD, for table mounting
 Inclusive holder for table duct.

Ø 50 mm		
Reach	1.300 mm	072-0400
Reach	1.500 mm	072-0401
Ø 75 mm		
Reach	1.300 mm	072-0402
Reach	1.500 mm	072-0403

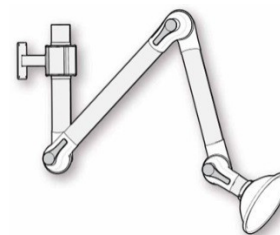

Suction arm ESD, for ceilings and wall mounting

Including wall / ceiling bracket

Ø 50 mm		
Reach	1.300 mm	072-0404
Reach	1.500 mm	072-0405
Ø 75 mm		
Reach	1.300 mm	072-0406
Reach	1.500 mm	072-0407

Suction arms and options

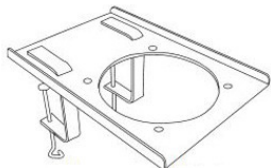
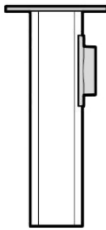
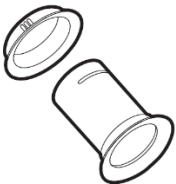
	<p>Universal console</p> <p>Bracket / console for the extraction arm of EVOTEC industrial vacuum cleaners. Ø 50 mm 053-3051 Ø 75 mm 053-3061</p>
	<p>Flexible table console ESD</p> <p>Holder/Console for mounting the arm on a (table-)plate, universal for</p> <p>Ø 50 mm / Ø 75 mm 072-0428</p>
	<p>Ceiling console ESD</p> <p>Universal holder/console for arm Ø 50 mm and Ø 75 mm, diverse lengths:</p> <p>Length 250 mm 072-0418 Length 500 mm 072-0419 Length 750 mm 072-0420 Length 1000 mm 072-0421</p> <p>Further lengths on request</p>
	<p>Straight hood tube ESD</p> <p>Spare part for hood, also usable as straight inlet nozzle.</p> <p>Ø 50 mm 072-0429 Ø 75 mm 072-0430</p>

Hoods and nozzles

	<p>Flat hood ESD, 300 x 200 mm</p> <p>Specially provided for gases and steams. High suction efficiency when positioned vertically to table surface, including socket</p> <p>Ø 50 mm 072-0414 Ø 75 mm 072-0415</p>
	<p>Aspiration tip, length 300 mm</p> <p>For smaller, concentrated contaminant sources. High efficiency, because it can be brought very close without disturbing the work flow. Cantilever of the tip for increasing the efficiency.</p> <p>Ø 50 mm 072-0410 Ø 75 mm 072-0411</p>
	<p>Flexible aspiration tip, length 600 mm, ESD</p> <p>High efficiency paired with high flexibility.</p> <p>Ø 50 mm 072-0412 Ø 75 mm 072-0413</p>

(All Ø specifications refer to the inner hose diameter)

PP- hose and - components

Made of polypropylene (PP), antistatic, with suitable fittings.
Well suitable for the industrial usage.



PP-suction hose
antistatic, complete with fittings

Length 3,5 m Ø 40 mm = **052-0151**
Length 3,5 m Ø 50 mm = **052-0248**
Length 5 m Ø 40 mm = **052-0152**
Length 5 m Ø 50 mm = **052-0249**



Linear meters
(for extension or self-manufacturing)

Ø 40 mm = **052-0130**
Ø 50 mm = **052-0230**



Fitting (suction side)
for **PP-hose** antistatic

Ø 40 mm = **052-0140**
Ø 50 mm = **052-0240**



Fitting (vessel side) for PP-hose antistatic
incl. retaining ring

Ø 80 - 40 mm = **052-0159**
Ø 80 - 50 mm = **052-0256**
only ECODust/Compact

Ø 60 - 40 mm = **052-0145**
Ø 60 - 50 mm = **052-0244**

Superflex-hose and - components

Made of polypropylene (PP), thread-strengthened and spiral-protected. Extra light and flexible also for longer distances. Well-suitable for industrial usage.

Discharging = when spiral is grounded

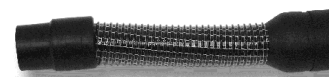

Superflex-suction hose,
electrically conductive, complete with fittings

Length 3,5 m Ø 40 mm = **052-0153**
Length 3,5 m Ø 50 mm = **052-0250**
Length 5 m Ø 40 mm = **052-0154**
Length 5 m Ø 50 mm = **052-0251**

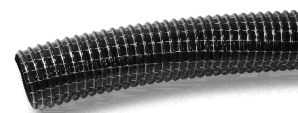

Linear meters
(for extension or self-manufacturing)

Ø 40 mm = **052-0133**
Ø 50 mm = **052-0136**
Ø 60 mm = **054-90037**



Fitting (suction side)
for **Superflex-hose** antistatic

Ø 40 mm = **052-0139**
Ø 50 mm = **052-0239**



Fitting (vessel side) for Superflex-hose
antistatic, incl. retaining ring

Ø 80 - 40 mm = **052-0158**
Ø 80 - 50 mm = **052-0255**
only ECODust/Compact

Ø 60 - 40 mm = **052-0144**
Ø 60 - 50 mm = **052-0243**

(All Ø specifications refer to the inner hose diameter)

PUR-hose and - components

Made of polyurethane (PUR). Enhanced by integrated steel spiral. Oil-resistant, sturdy and suitable for abrasive dusts. Heat proof up to 125°C. Well-suited for extreme industrial usage.

Discharging = when spiral is grounded

	<p>PUR-suction hose, electrically conductive, complete with fittings</p> <p>Length 3,5 m Ø 40 mm = 052-0155 Length 3,5 m Ø 50 mm = 052-0252 Length 5 m Ø 40 mm = 052-0156 Length 5 m Ø 50 mm = 052-0253</p>
	<p>Linear meters (for extension or self-manufacturing)</p> <p>Discharging when spiral is grounded</p> <p>Ø 40 mm = 052-0136 Ø 50 mm = 052-0236 Ø 70 mm = 052-0309</p> <p>Reinforced version:</p> <p>Ø 40 mm = 052-0157 Ø 50 mm = 052-0254 Ø 70 mm = 052-0310</p>
	<p>Fitting (suction side) for PUR-hose antistatic</p> <p>Ø 40 mm = 052-0141 Ø 50 mm = 052-0241 Ø 70 mm = 052-0311</p>
	<p>Fitting (boiler side) for PUR-hose antistatic incl. Retaining ring</p> <p>Ø 80 - 40 mm = 052-0160 Ø 80 - 50 mm = 052-0257</p> <p>only ECODust/Compact</p> <p>Ø 60 - 40 mm = 052-0146 Ø 60 - 50 mm = 052-0245</p>

ESD-hose and - components

Hose material: polyurethane (PUR) or polypropylene (Superflex). Both spiral-supported, Superflex additionally reinforced with thread. Ideally suited material for industrial use in potentially explosive atmospheres.

Completely electrically conductive 10³ to 10⁴ Ω

	<p>ESD-Superflex-suction hose Completely electrically conductive 10⁴ Ω</p> <p>Ø 40 mm = 052-0200 Ø 50 mm = 052-0287</p>
	<p>ESD-PUR-suction hose Completely electrically conductive 10³ Ω</p> <p>Ø 40 mm = 052-0196 Ø 50 mm = 052-0281</p>
	<p>Fitting (suction side)</p> <p>for ESD-Superflex-suction antistatic</p> <p>Ø 40 mm = 052-0139 Ø 50 mm = 052-0239</p> <p>for ESD-PUR-suction antistatic</p> <p>Ø 40 mm = 052-0141 Ø 50 mm = 052-0241</p>
	<p>Fitting (boiler side) for ESD-Superflex-suction hose antistatic incl. Retaining ring</p> <p>Ø 80 - 40 mm = 052-0158 Ø 80 - 50 mm = 052-0255</p> <p>for ESD-PUR-suction hose antistatic</p> <p>Ø 80 - 40 mm = 052-0160 Ø 80 - 50 mm = 052-0257</p>

Practical accessory sets

Machine cleaning kit

optimized for the cleaning of production machines, complete antistatic

Consisting of bulk suction nozzle, inclined tube rubber nozzle and pointed rubber nozzle



Ø 40 mm **052-1081**
 Ø 50 mm **052-1071**

Industrial floor cleaning kit

for the cleaning of all floors, complete antistatic



Consisting of multi-part hand tube, metal revolving nozzle with brush strip and replacement rubber strips

Ø 40 mm, width 370 mm **052-1031**
 Ø 40 mm, width 450 mm **052-1036**
 Ø 50 mm, width 370 mm **052-1041**
 Ø 50 mm, width 450 mm **052-1051**
 Ø 50 mm, width 500 mm **052-1061**



[You Tube](#)

Set for cleaning at altitude



for the cleaning in heights, e.g. supply tubes





consisting of 4 hand tubes Ø40mm, each 500mm long (052-1100 including connector from Ø40 to Ø50mm), curved tubular nozzles 100 mm and 200 mm, as well as a wall- and floor nozzle

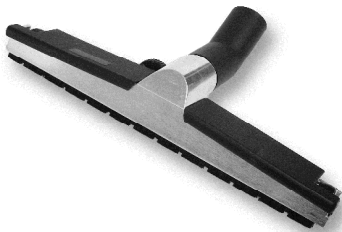

Ø 40 mm **052-1090**
 Ø 50 mm **052-1100**

Accessories	
	<p>Ex Curved tube, chrome-plated</p> <p>Ø 36 mm = 052-0014 Ø 40 mm = 052-0111 Ø 50 mm = 052-0209</p>
	<p>Ex Hand tube, chrome plated</p> <p>Ø 36 x 500 mm = 052-0012 Ø 40 x 500 mm = 052-0112 Ø 50 x 500 mm = 052-0208</p>
	<p>Floor nozzle with brush strip and lateral rollers</p> <p>Ø 40 x 400 mm = 052-0116 Ø 50 x 400 mm = 052-0210</p> <p>Brush strip for replacement = 052-0026</p>
	<p>Floor nozzle with rubber strip and lateral rollers</p> <p>Ø 40 x 400 mm = 052-0117 Ø 50 x 400 mm = 052-0211</p> <p>Rubber strip for replacement = 052-0027</p>

Accessories	
	<p>Floor nozzle with carpet strip and lateral rollers</p> <p>Ø 40 x 400 mm = 052-0118</p> <p>Rubber strip for replacement = 052-0030</p>
	<p>Ex Robust Alu-floor nozzle with rollers and brush strip</p> <p>Ø 40 x 370 mm = 052-0120 Ø 40 x 450 mm = 052-0121 Ø 50 x 370 mm = 052-0213 Ø 50 x 450 mm = 052-0214 Ø 50 x 500 mm = 052-0215</p> <p>with rollers and rubber strip</p> <p>Ø 40 x 370 mm = 052-0192 Ø 40 x 450 mm = 052-0193 Ø 50 x 370 mm = 052-0276 Ø 50 x 450 mm = 052-0277</p>
	<p>Brush strip for replacement</p> <p>Length 370 mm = 052-0173 Length 450 mm = 052-0171 Length 500 mm = 052-0264</p>
	<p>Rubber strip for replacement, oil resistant</p> <p>Length 370 mm = 052-0194 Length 450 mm = 052-0195 Length 500 mm = 052-0280</p>

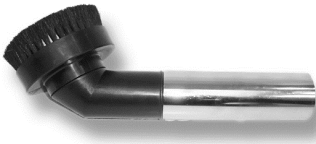
 - Accessories	
	<p>Flat rubber nozzle with connecting tube antistatic (Without extension tube can also be attached to hand pipe)</p> <p>Ø 40 mm = 052-0126 Ø 50 mm = 052-0223 Ø 70 mm = 052-0304</p>
	<p>Pointed rubber nozzle with connecting tube antistatic (Without extension tube can also be attached to hand pipe)</p> <p>Ø 40 mm = 052-0124 Ø 50 mm = 052-0221</p>
	<p>Inclined tube rubber nozzle antistatic (Without extension tube can also be attached to hand pipe)</p> <p>Ø 40 mm = 052-0125 Ø 50 mm = 052-0222 Ø 70 mm = 052-0303</p>
	<p>Solid PP round brush Rubber with connection tube, broad brush head with brass components, antistatic</p> <p>Ø 40 mm = 052-0103 Ø 50 mm = 052-0205</p>

Accessories	
	<p>Hand tube set for cleaning at altitude</p> <p>Ø 40 x 2000 mm = 052-0113 Ø 50 x 2000 mm = 052-0216</p>
	<p>Curved tubular nozzle Also usable for cleaning at altitude Ø 40 mm</p> <p>Curve width 100 mm = 052-0122 Curve width 200 mm = 052-0123</p>
	<p>Wall-and floor nozzle with brush strips</p> <p>Ø 40 x 300 mm = 052-0114</p>
	<p>Wall-and floor nozzle with rubber strips</p> <p>Ø 40 x 300 mm = 052-0115</p>

Metal-hoses and - components

Made of metal, reinforced with metal bands and sealing threads.

Axial flexible, torsionally rigid, heat proof up to 400° C.

Suitable for dry dusts only.

	<p>Metal-suction hose fiberglass-compressed, complete with fittings</p> <p>Length 3,5 m Ø 40 mm = 052-0186 Length 3,5 m Ø 50 mm = 052-0271 Length 5 m Ø 40 mm = 052-0187 Length 5 m Ø 50 mm = 052-0272</p>
	<p>Linear meters (for extension or self-manufacturing)</p> <p>Ø 40 mm = 052-0185 Ø 50 mm = 052-0270</p>
	<p>Universal fitting (boiler side), usable for all hose types</p> <p>Ø 80 - 40 mm = 052-0175 Ø 80 - 50 mm = 052-0266 Ø 80 - 60 mm = 054-90013 Ø 80 - 70 mm = 052-0312 Ø 80 - 80 mm = 052-0322</p>
	<p>Fitting (suction side) for Metal hose</p> <p>Ø 40 mm = 052-0112 Ø 50 mm = 052-0208</p>

- Accessories

	<p>Crevice nozzle, metal</p> <p>Ø 40 x 300 mm = 052-0109 Ø 40 x 500 mm = 052-0108 Ø 40 x 800 mm = 052-0107 Ø 50 x 300 mm = 052-0218 Ø 50 x 600 mm = 052-0219</p>
	<p>Inclined tube nozzle, metal</p> <p>Ø 40 x 300 mm = 052-0110 Ø 50 x 300 mm = 052-0217</p>
	<p>Crevice nozzle metal, curved</p> <p>Ø 50 mm = 052-0220</p>
	<p>Rubber crevice nozzle, with connecting tube antistatic</p> <p>Ø 40 x 400 mm = 052-0150 Ø 50 x 430 mm = 052-0203</p>

Disposal									
Dirt container from stainless steel High quality stainless steel 1.4301 for sturdy usage and suitable for hygienic sensitive areas with comfortable lowering for easy disposal of the absorbed matter									
dirt container 35 liter	■						■		
dirt container 60 liter		■	■	■					
dirt container 100 liter					■	■		■	■
Longopac- disposal system "Endless"-plastic disposal bag for contamination free and easy disposal of the absorbed matter			□	□	□		■/□	■/□	■/□
Automatic fill level control rotating paddle sensor monitors the filling level of the dry dust in the dirt container	□	□	□	□	□	□	□	□	□
Accessory included in delivery									
Suction hose sturdy and flexilbe quality for mobile working									
- 3,5 m, Ø 50 mm	■	■	■	■		■	■	■	■
- 5 m, Ø 50 mm					■/□				
Crevice nozzle for various suction tasks									
- Ø 50 mm	■	■	■	■	■/□	■	■	■	■



EVOTEC

Your advantages:

- Top quality – professional manufacturing
- Heavy duty and long-living materials
- Convincing functionality and ergonomics
- Unexpected new solutions
- Flexible and economical in use
- Reliability from more than 30 years
- High aspiration in design and operator convenience

