

# OSKAR

## air products

www.oskarairproducts.com • info@oskarairproducts.com

### Rollout - mobile cartridge filter unit

- 303101967**
- main filter cartridge 18.3 m<sup>2</sup>
  - fan 1,1 kW, 50 Hz, 3-phase, 400 V

Mobile filter unit designed for continuous operation at heaviest and most demanding applications.

#### Standard construction:

- aluminum impeller 1,1 kW fan unit
- three stage filtration
- standard manual compressed air cartridge cleaning system
- easy access dust drawers
- heavy duty welded and powder coated construction
- 10 litre compressed air tank

#### Parameters:

nominal airflow:	1000 m <sup>3</sup> /h
main filter surface:	18,3 m <sup>2</sup>
weight:	125 kg
power supply:	3 x 400V / 50Hz
motor power:	1,1 kW
rated current:	2,7 A

#### Accessories and options:

- Oskar fume arm 1620P, reach 2 m , hood inlet 315 mm
- Oskar fume arm 1630P, reach 3 m, hood inlet 315 mm
- timer controlled compressed air cleaning operation

#### Spare parts:

- main filter cartridge 18,3 m<sup>2</sup>
- main filter cartridge 12 m<sup>2</sup>
- outlet filter (activated carbon impregnated material)
- metal mesh pre-filter
- swivel caster with brake 125
- wheel 160

#### The method of packing and carton sizes:

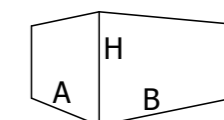

A = 780  
B = 745  
H = 1440  
weight = 125 kg

All dimensions are given in mm.

Menegon Sp z o.o.  
Mokry Dwór 6C, 80-021 Wiślina, Polska  
tel.: +48 58 3012838, fax +48 58 3059324  
info@menegon.com.pl, www.menegon.com.pl

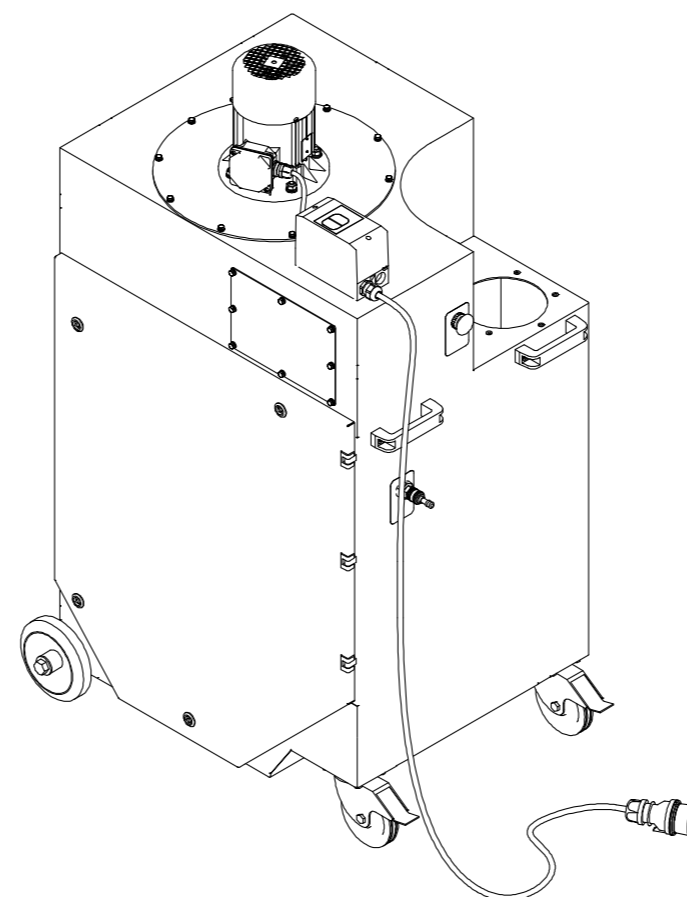
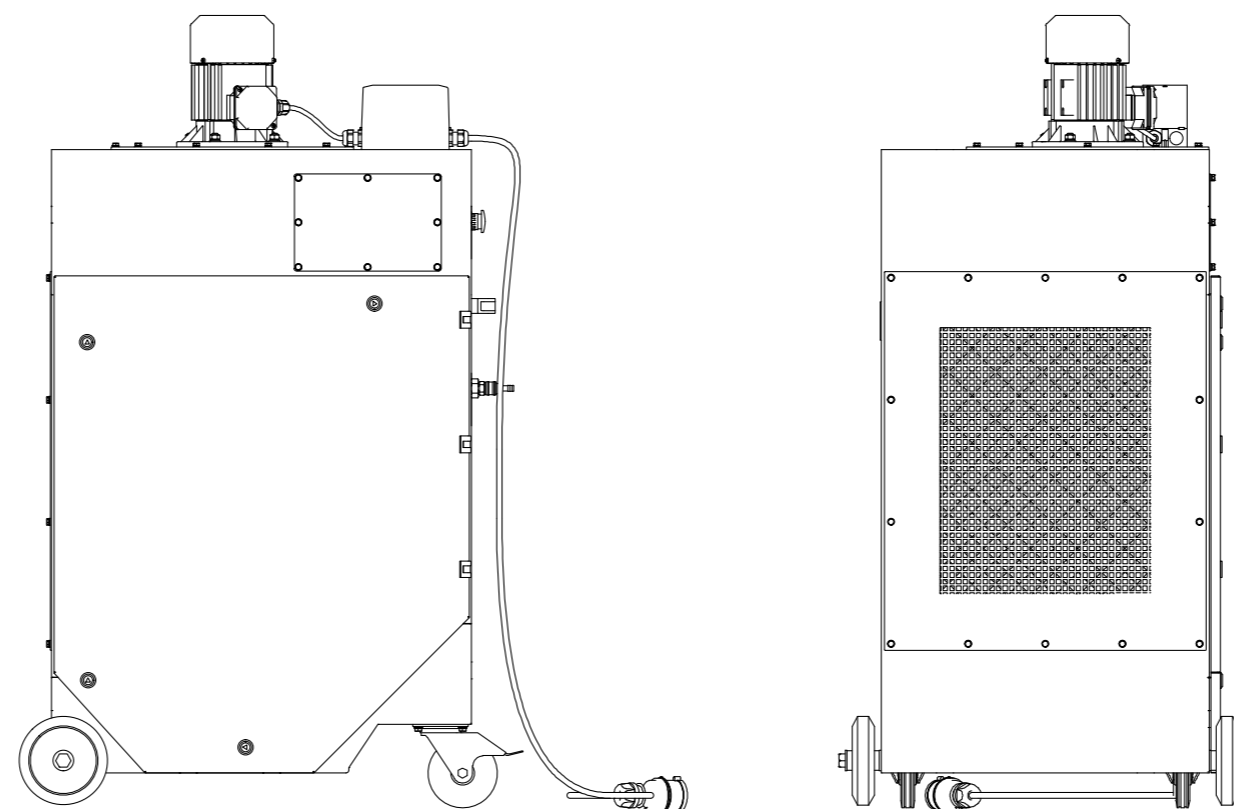
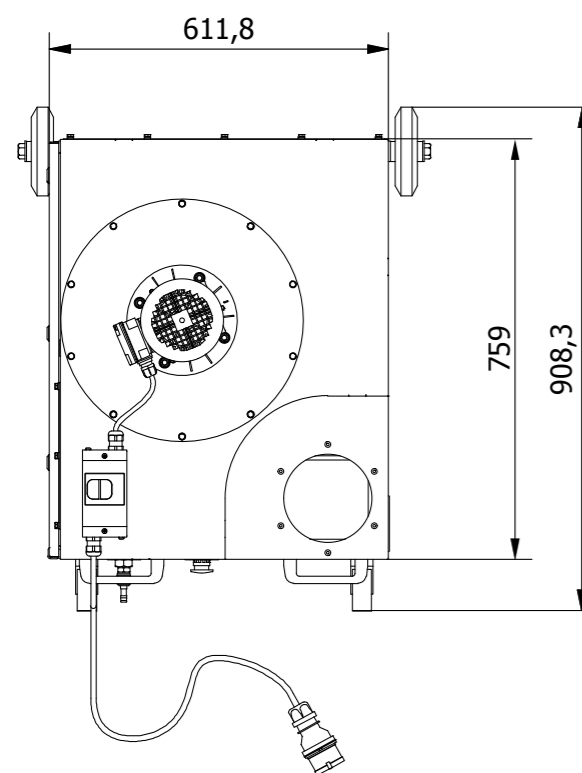
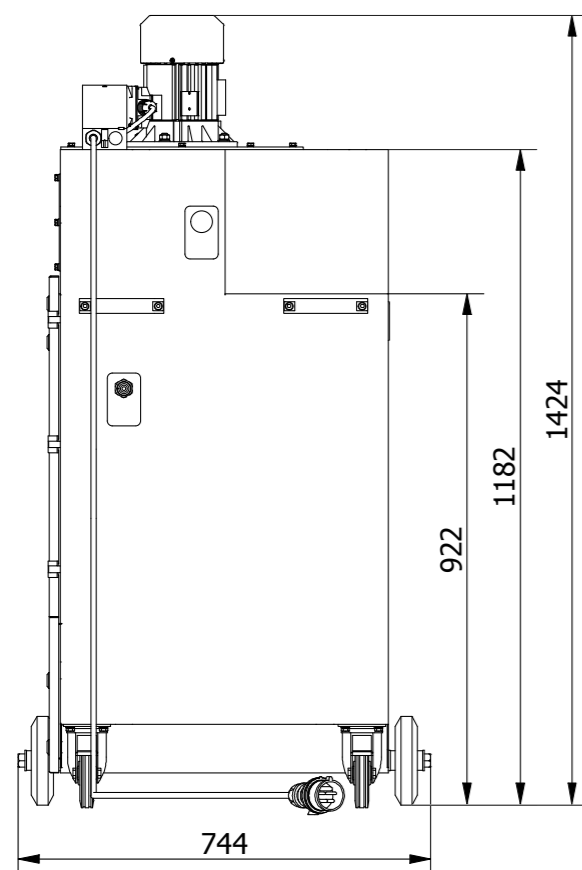

All rights reserved. This document including constructional and technical information as well as Oskar Air Products, Menegon and czystepowietrze.pl trademarks and brand names are law protected and are property of Menegon Sp. z o.o.